

MECHANICAL BIN CONTROL
(SHOWN INSTALLED)

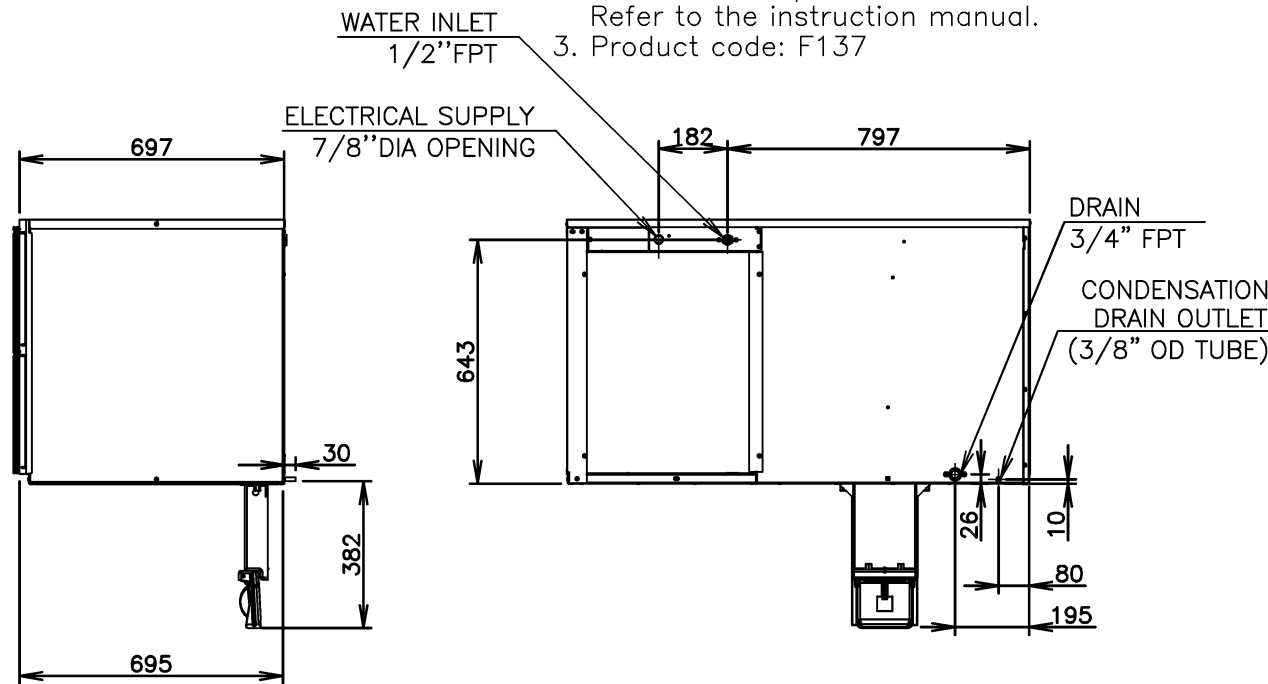
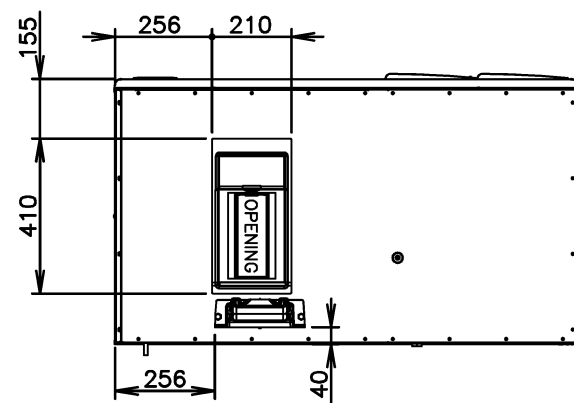

ICE MAKER PROTECTION	Interlock by Controller Board
WEIGHT	Net weight 136kg/Gross weight 154kg
PACKAGE	1,312mm (W) x 843mm (D) x 850mm (H)
ACCESSORIES	Instruction Manual, Universal bruce(2) Bolt(5),Thumbscrew
OPERATION CONDITION	Ambient Temp. : 7-38°C, Water Supply Temp. : 7-32°C Water Supply Pressure: 0.07-0.78MPa (0.7-7.8bar) Voltage Range:198-254V

- *We reserve the right to make changes in specifications and design without prior notice.
1. Install the product properly in accordance with the instructions on location, water supply/drain connections and electrical connections stated in the instruction and installation manuals provided.
 2. The ice production depends on the ambient and water temperatures. Refer to the instruction manual.
 3. Product code: F137

ITEM	Hoshizaki Crescent Ice Maker
MODEL	KM-590DJ
AC SUPPLY VOLTAGE	1 Phase 220-240V 50Hz
AMPERAGE	11.35A (AT. 32°C, WT. 21°C)
STARTING AMPERAGE	58A
ELECTRICAL CONSUMPTION	2,080W (AT. 32°C, WT. 21°C)
POWER FACTOR	80%
POWER SUPPLY CAPACITY	3.64kVA (15.8A)
ICE PRODUCTION PER 24H	Approx. 630kg/d (AT. 10°C, WT. 10°C) Approx. 590kg/d (AT. 21°C, WT. 15°C) Approx. 500kg/d (AT. 32°C, WT. 21°C)
WATER CONSUMPTION PER 24H	Approx. 2.41m ³ /d (AT. 10°C, WT. 10°C) Approx. 1.15m ³ /d (AT. 21°C, WT. 15°C) Approx. 1.17m ³ /d (AT. 32°C, WT. 21°C)
SHAPE OF ICE	Crescent Cube
FREEZE CYCLE TIME	Approx. 28Min (AT. 21°C, WT. 15°C)
ICE PRODUCTION PER CYCLE	Approx. 12.9kg/1,440pcs (AT. 21°C, WT. 15°C)
OUTSIDE DIMENSIONS	1,219mm (W) x 695mm (D) x 695mm (H)
EXTERIOR	Stainless Steel, Galvanized Steel (Rear)
INSULATION	Polyurethane Foam
INSULATION FOAM BLOWING AGENT	Cyclopentane
CONNECTIONS-ELECTRIC	PERMANENT CONNECTION(CONDUIT)
CONNECTIONS-WATER SUPPLY	Inlet 1/2"FPT(connected at rear side)
CONNECTIONS-DRAIN	Outlet 3/4"FPT(connected at rear side)
CONNECTIONS-CONDENSATE DRAIN	3/8" OD TUBE
ICE MAKING SYSTEM	Vertical Evaporator with water flow on both sides
HARVESTING SYSTEM	Water Supply Harvest Cycle and Hot Gas Defrost
COMPRESSOR	Hermetic
CONDENSER	Air-cooled, Fin and Tube type
HEAT REJECTION	4,720W (AT. 32°C, WT. 21°C)
EVAPORATOR	Vertical type, Stainless Steel and Copper
REFRIGERANT CONTROL	Thermostatic Expansion Valve
REFRIGERANT CHARGE	R404A/1,900g
ICE MAKING CONTROL SYSTEM	Float Switch
HARVESTING CONTROL SYSTEM	Hot Gas and Water, Thermistor and Timer
ICE MAKING WATER CONTROL SYSTEM	Timer Controlled, Overflow Pipe
BIN CONTROL SYSTEM	Mechanical Bin Switch
ELECTRICAL PROTECTION	Class I Appliance, 10A Fuse
P. C. BOARD CIRCUIT PROTECTION	High Voltage Cut-out (Internal)
COMPRESSOR PROTECTION	Auto-reset Overload Protector (Internal)
REFRIGERANT CIRCUIT PROTECTION	Auto-reset High Pressure Control Switch
LOW WATER PROTECTION	Float Switch

HOSHIZAKI CRESCENT ICE MAKER KM-590DJ (STACKABLE TYPE)

APPROVED YAMAGUCHI	CHECKED TIAN	DESIGNED WG	DRAWN WG	SCALE 1/20	TRIGONOMETRY
*	*	△	*****	DATE 2019.06.05	DRAWING NO. D25323
APPROVED	DESIGNED	SYMBOL	DATE		SYMBOL △