



HOSHIZAKI

> **KMD-201AA**

daily ice production capacity of up to 205kg



Crescent-shaped ice moves around freely yet packs together tightly in its bin, maximising storage capacity. Individual crescents do not stick together as there are no air pockets so that each piece of ice comes across distinctive in a cup of drink. This unit can be fitted on a dispenser for quick and ease-of- access.



> **KMD-201AA**
(With Hoshizaki Storage
Bin - **B-301SA**)

CRESCENT ICE MAKER SERIES

FEATURES

- > stainless steel evaporator
- > audible controller board
- > easy cleaning with pull out filter & removable water tank
- > low 53db noise level
- > fitted with reliable mechanical proximity bin control switch
- > cyclesaver® design 
- > evercheck® alert 
- > compartmentalised internal design
- > able to be installed on 560mm (22") wide drink dispenser

ICE SIZE

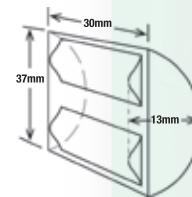

Crescent Ice Maker **KMD-201AA**

Allows installation
on 560mm(22")wide
drink dispenser.



DIMENSIONS & SPECIFICATION

CRESCENT ICE MAKER AIR SYSTEM

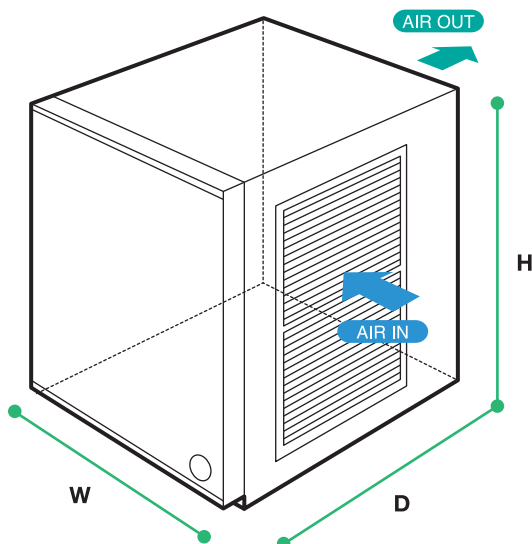

BACK SIDE

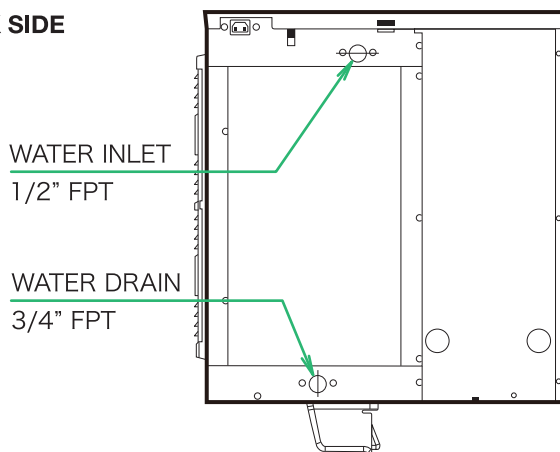

MODEL NAME		KMD-201AA
ICE DIMENSIONS (MM)		37 x 30 x 13
DIMENSIONS (MM)		560 x 625 x 610
PACKED DIMENSIONS (MM)		668 x 727 x 793
WEIGHT (NETT/GROSS)		57 KG / 73 KG
AMPERAGE / STARTING AMPERAGE		3.0A / 25A
ELECTRICAL CONSUMPTION		700 W / 810 W
REFRIGERANT CHARGE		R134a
HEAT REJECTION		1410 W (1220 kcal/h)
ICE PRODUCTION PER 24H (15MM)	(AT10°C/WT10°C)	205 KG
	(AT21°C/WT15°C)	182 KG
	(AT32°C/WT21°C)	157 KG
WATER CONSUMPTION PER 24H (AT21°C/WT15°C)		0.48 m ³ 2.6L / 1KG ICE
ICE PRODUCTION (AT21°C/WT15°C)	FREEZE CYCLE TIME	27.7 MIN
	PER CYCLE	3.8 KG / 416 PCS

NOTE: All dimensions indicated are Width x Depth x Height in mm.

OPERATING CONDITIONS: • Voltage Range: 198V-254V • Ambient Temperature: 1°-40°C
• Water Supply: 7°-35°C / 0.07-0.8 Mpa / 7.25-116 PSI • AC Supply Voltage: 1/220-240V / 50 Hz

• **WARRANTY:** Two years parts & labour for entire unit, 3rd year on compressor only. Excluding door & exterior damages